



Finishing Mower FP-148, FP-160 and FP-172



Parts Manual

Locke Turf

307 Highway 52E, Opp, Alabama 36467, (334) 493-1300

Transport Wheel, Tire & Spindle FP

ALPHABETICAL INDEX

CONTENTS	PAGE
Base Frame FP148, FP160 and FP172	3-1
Belts, Drive FP148, FP160 and FP172	3-2
Caster Arm (All Models)	4-2
Decals; Safety, Warning, Danger	1-1
Driveshaft Assembly (All Models)	3-2
Mast & Support (3 Pt Lift)	4-1
Mulching Assembly	2-2
Pulleys (Drive & Idlers)	2-1
Roller, Front & Under Side	4-3
Shields, Safety	1-1
Spindle Assembly	2-3
Wheel & Fork Assembly	4-2
Wrench Kit	2-3

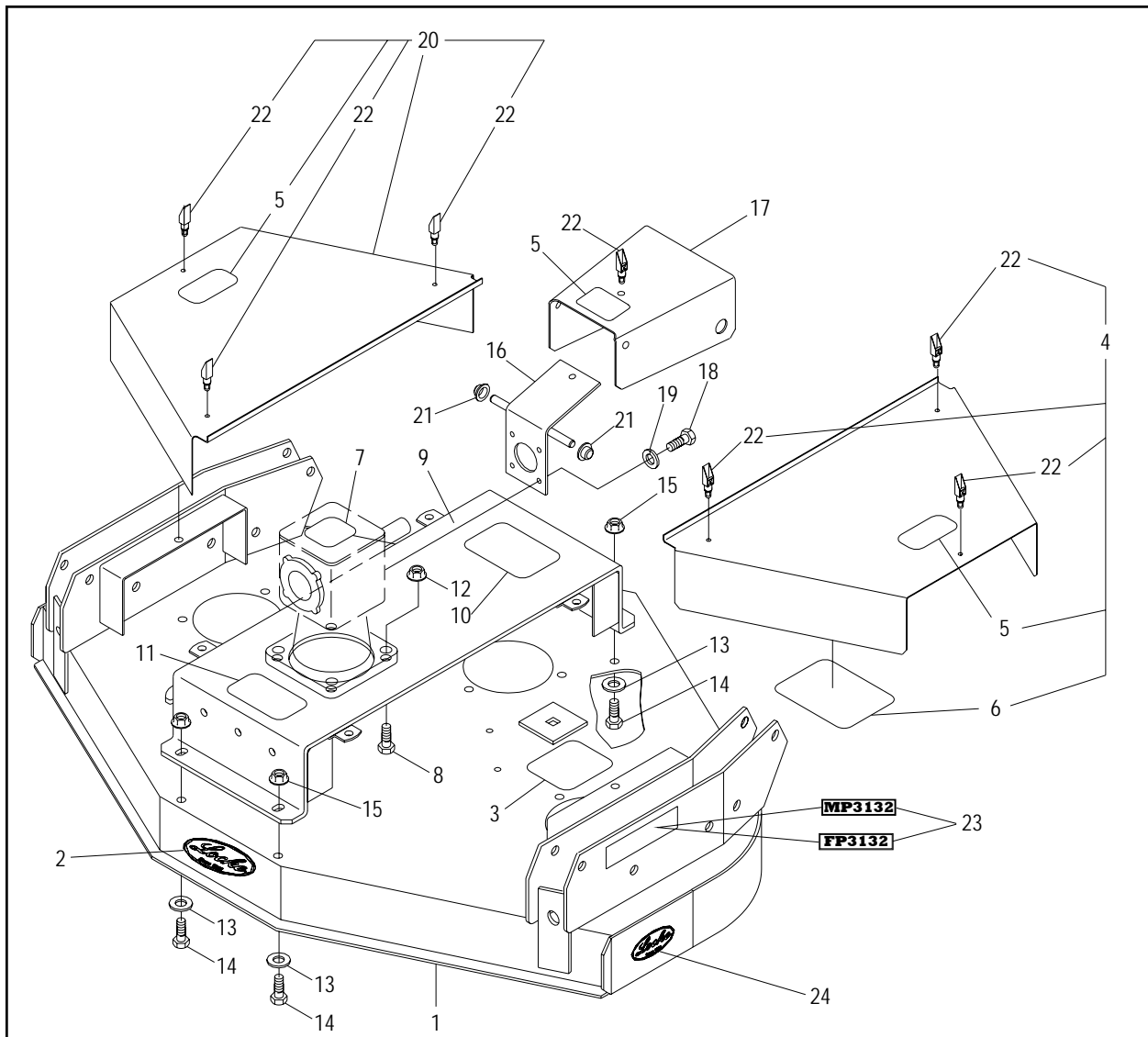

Base Frame & Shielding

REF. NO.	PART NO.	QTY	DESCRIPTION	REF. NO.	PART NO.	QTY	DESCRIPTION
1	50018786	1	60" Deck w/Decals	14	1056	4	HHCS 1/2" x 1-1/4" Gr.5
	50018787	1	72" Deck w/Decals	15	19518	4	Locknut, Flange 1/2"
2	500033	1	Decal, Locke (Large)	16	98253	1	Shield Mount Bracket
3	50012616	2	Decal, Danger	17	98174	1	Shield w/Decal
4	99498	1	R.H. Shield w/Decals	18	44215	4	HHCS M8 x 1.25 x 15mm
5	50012615	3	Decal, Warning	19	44311	4	Lockwasher M8
6	98082	2	Decal. Belt Installation	20	99499	1	L.H. Shield w/Decals
7	89477	1	Decal, Warranty	21	50014067	2	Cap
8	15165	3	HHCS 5/8" x 1-3/4"	22	98284	7	Swell Latch
9	50021133	1	Gearbox Stand w/Decal	23	50100006	1	Decal, Model
10	83105	1	Decal, Warning	24	500034	2	Decal, Locke (Small)
11	82619	1	Decal, Danger				
12	20414	4	Locknut, Flange 5/8"				
13	15916	4	Flatwasher 1/2"				

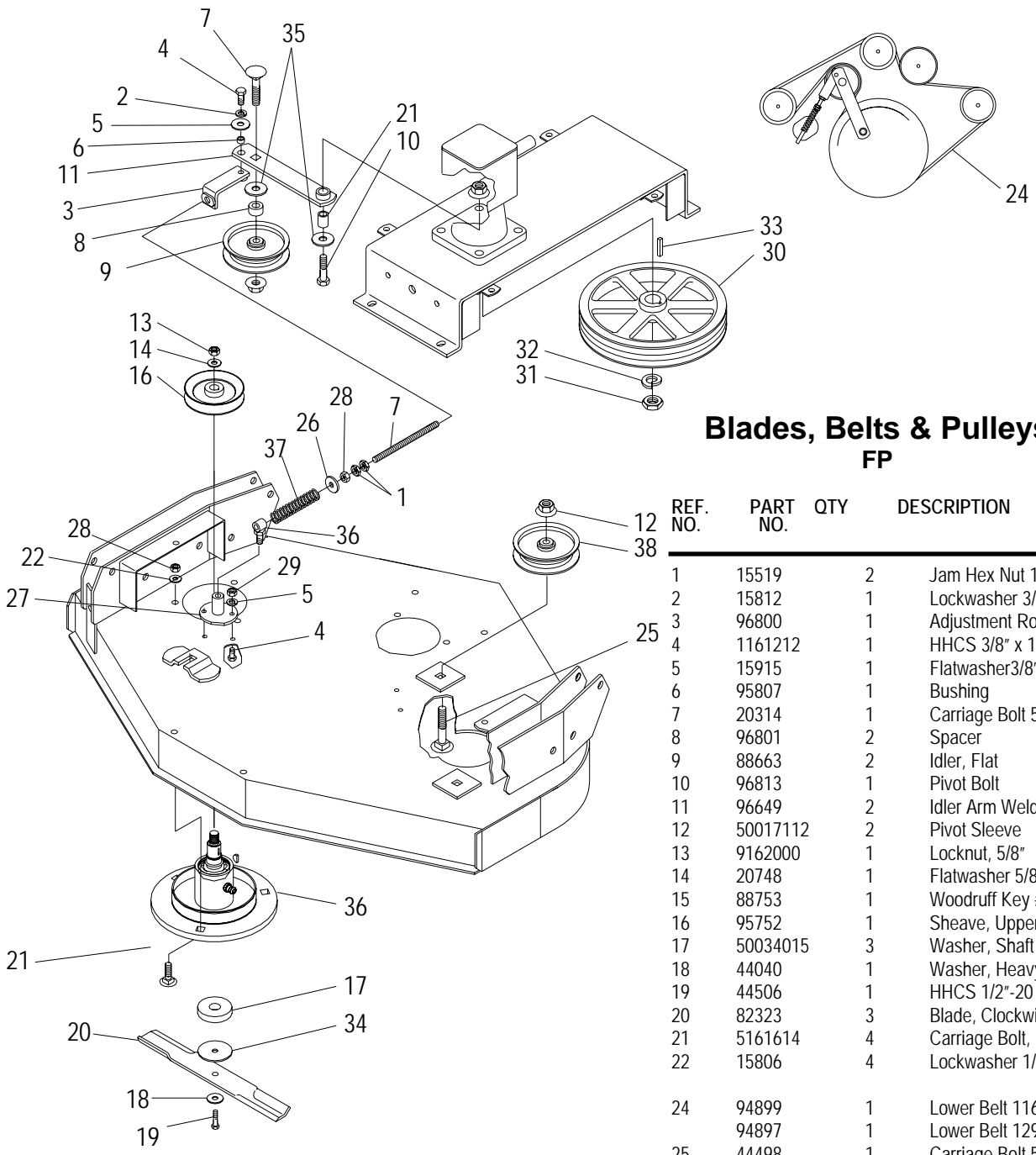

Blades, Belts & Pulleys FP

REF. NO.	PART NO.	QTY	DESCRIPTION
1	15519	2	Jam Hex Nut 1/2"
2	15812	1	Lockwasher 3/8"
3	96800	1	Adjustment Rod Weldment
4	1161212	1	HHCS 3/8" x 1-1/4"
5	15915	1	Flatwasher 3/8"
6	95807	1	Bushing
7	20314	1	Carriage Bolt 5/8" x 3"
8	96801	2	Spacer
9	88663	2	Idler, Flat
10	96813	1	Pivot Bolt
11	96649	2	Idler Arm Weldment
12	50017112	2	Pivot Sleeve
13	9162000	1	Locknut, 5/8"
14	20748	1	Flatwasher 5/8"
15	88753	1	Woodruff Key #606
16	95752	1	Sheave, Upper
17	50034015	3	Washer, Shaft
18	44040	1	Washer, Heavy Duty
19	44506	1	HHCS 1/2"-20 UNF x 1-3/4"
20	82323	3	Blade, Clockwise 17"
21	5161614	4	Carriage Bolt, 1/2" x 1-1/2"
22	15806	4	Lockwasher 1/2"
24	94899	1	Lower Belt 116" (60" Model)
	94897	1	Lower Belt 129" (72" Model)
25	44498	1	Carriage Bolt 5/8" x 4-1/2"
26	15916	2	Flatwasher 1/2"
27	96816	2	Pivot Mount Weldment
28	8151600	1	Hex Nut 1/2"
29	8151200	1	Hex Nut 3/8"
30	94906	1	Sheave 15.16" Dia. (60" Model)
	94908	1	Sheave 12.79" Dia. (72" Model)
31	70287	1	Nut M30 x 2
32	70286	1	Lockwasher M30
33	70288	1	Key, Square
34	97658	A/R	Spacer
35	20748	2	Flatwasher 5/8"
36	98773	3	Spindle & Pulley Assembly See Page 10
36	95818	1	Pivot Weldment
37	95827	1	Spring
38	97111	1	V-Idler Pulley, 5.5" Dia

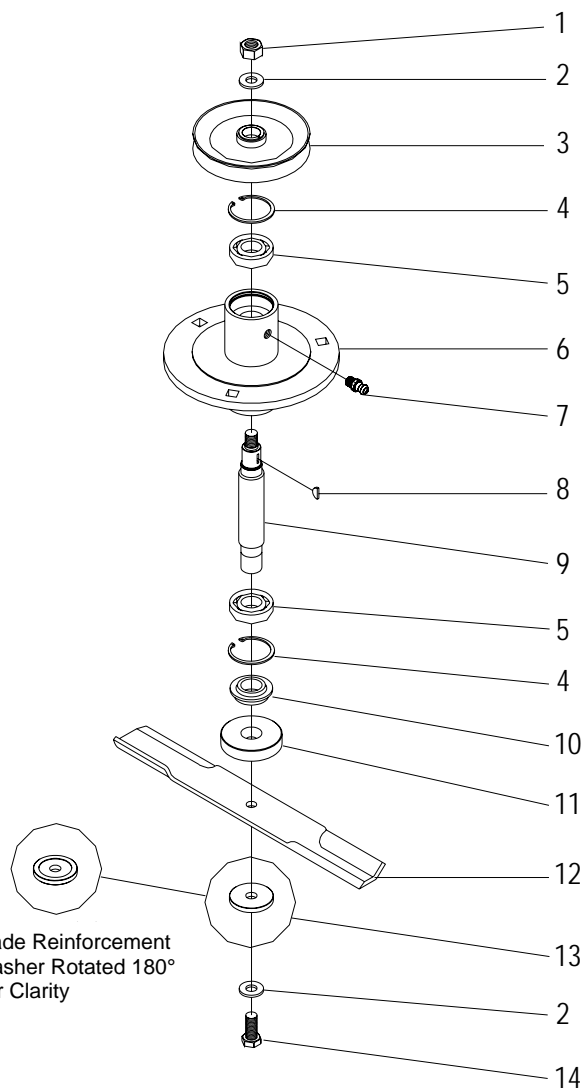

Blade Reinforcement
Washer Rotated 180°
For Clarity

REF. NO.	PART NO.	QTY	DESCRIPTION
1	9162000	1	Lock Nut 5/8"
2	20748	2	Flatwasher 5/8"
3	95752	1	Upper Sheave
4	97685	2	Snap Ring
5	95764	2	Bearing, Inner Shaft
6	50100001	1	Machined Housing Weldment
7	449	1	Grease Fitting
8	20593	1	Woodruff Key
9	95757	1	Shaft, Inner
10	50100049	1	Blade Bushing
11	50034015	1	Washer, Heavy Duty
12	82323	1	Blade
13	50100045	1	Washer, Heavy Duty
14	44506	1	HHCS 1/2"-20 UNF x 1-3/4"

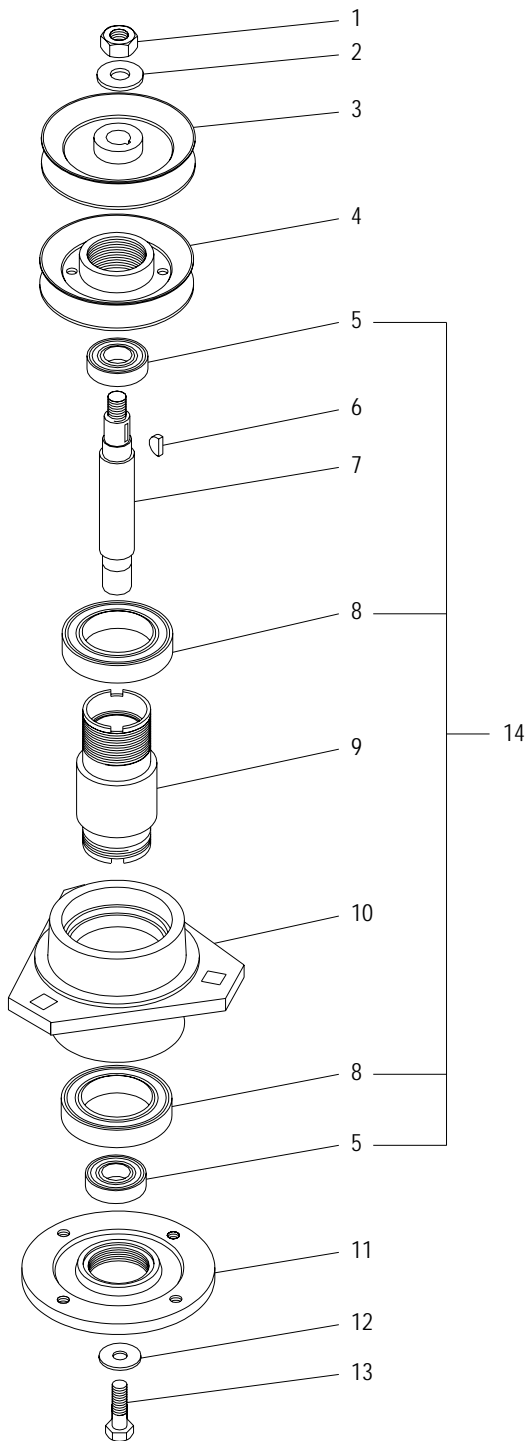

Blade Spindle MP

REF. NO.	PART NO.	QTY	DESCRIPTION
	98773	1	Replacement Spindle Assy. (Items 1-13)
1	9162000	1	Lock Nut 5/8"
2	20748	1	Flatwasher 5/8"
3	95752	1	Upper Sheave
4	96165	1	Lower Sheave
5	95764	2	Bearing, Inner Shaft
6	95757	1	Bearing, Outer Shaft
7	88753	1	Shaft, Inner
8	94953	2	Woodruff Key 606
9	96162	1	Blade Carrier
10	92924	1	Hub, Machined
11	96161	1	Blade Carrier
12	44040	1	Washer, Heavy Duty
13	44506	1	HHCS 1/2"-20 UNF x 1-3/4"
14	50026133	1	Bearing Kit

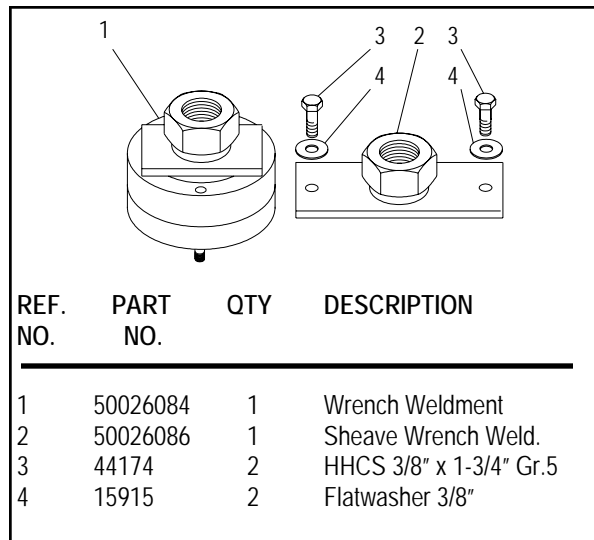

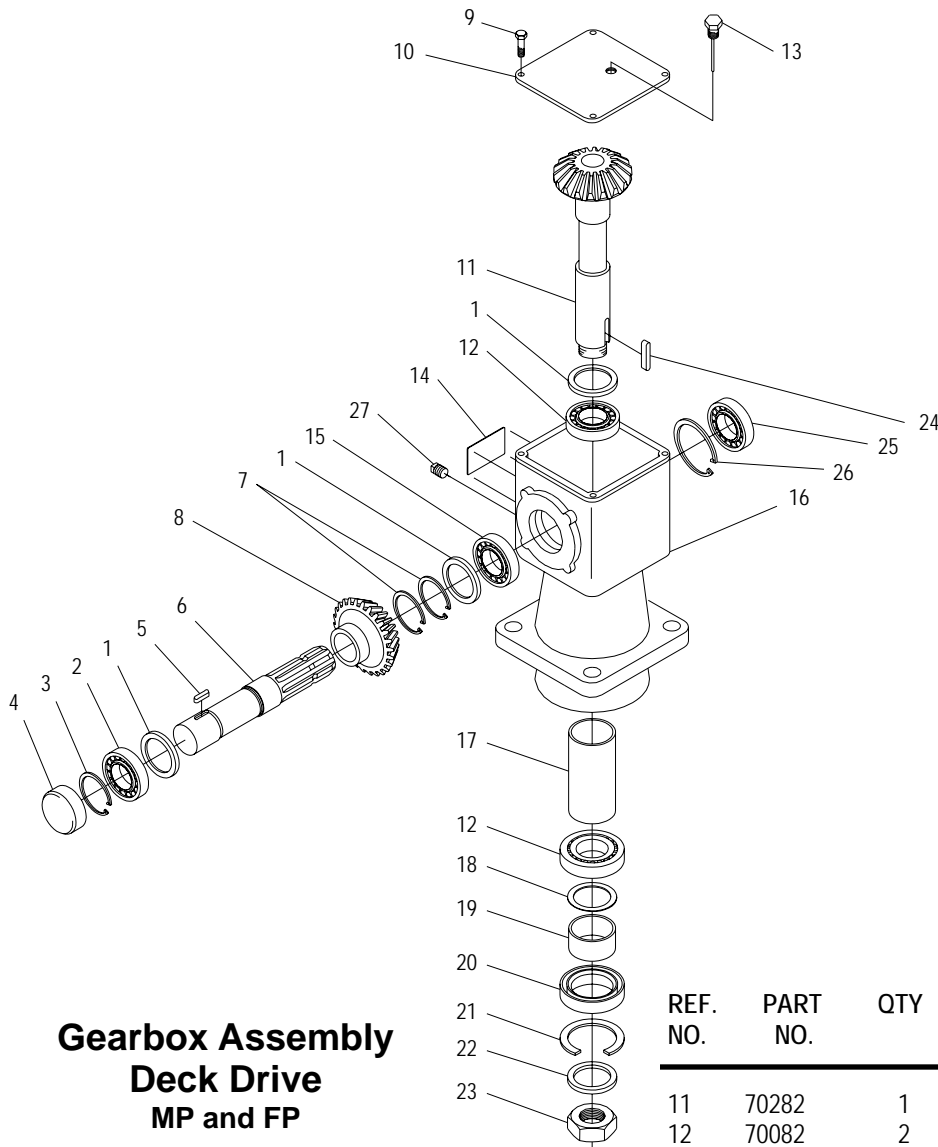

**Gearbox Assembly
Deck Drive
MP and FP**

REF. NO.	PART NO.	QTY	DESCRIPTION
1	70329	A/R	Shim .3mm
	70330	A/R	Shim .4mm
	70331	A/R	Shim .5mm
	70332	A/R	Shim 1.3mm
2	70107	1	Bearing
3	70133	1	Retaining Ring
4	70279	1	Cap
5	70226	1	Key M10 x 8 x 30
6	70281	1	Shaft
7	70110	2	Outside Retaining Ring
8	70094	1	Gear 26 Teeth
9	70326	4	HHCS M8 x 16
10	70092	1	Top Plate

REF. NO.	PART NO.	QTY	DESCRIPTION
11	70282	1	Pinion 12 Teeth
12	70082	2	Bearing
13	70393	1	Vent Plug
14	N/A	1	Serial Number Plate
15	70129	1	Bearing
16	70283	1	Housing
17	70284	1	Spacer Ring
18	70081	1	Gasket
19	70285	1	Bushing
20	70080	1	Seal
21	70079	1	Shoulder Ring
22	70286	1	Spring Washer
23	70287	1	Hex Nut
24	70288	1	Key 6 x 6 x 30 mm
25	70290	1	Seal
26	70291	1	Retaining Ring
*27	70152	1	Gasket

* Silicone Sealer may be used in place of gasket.

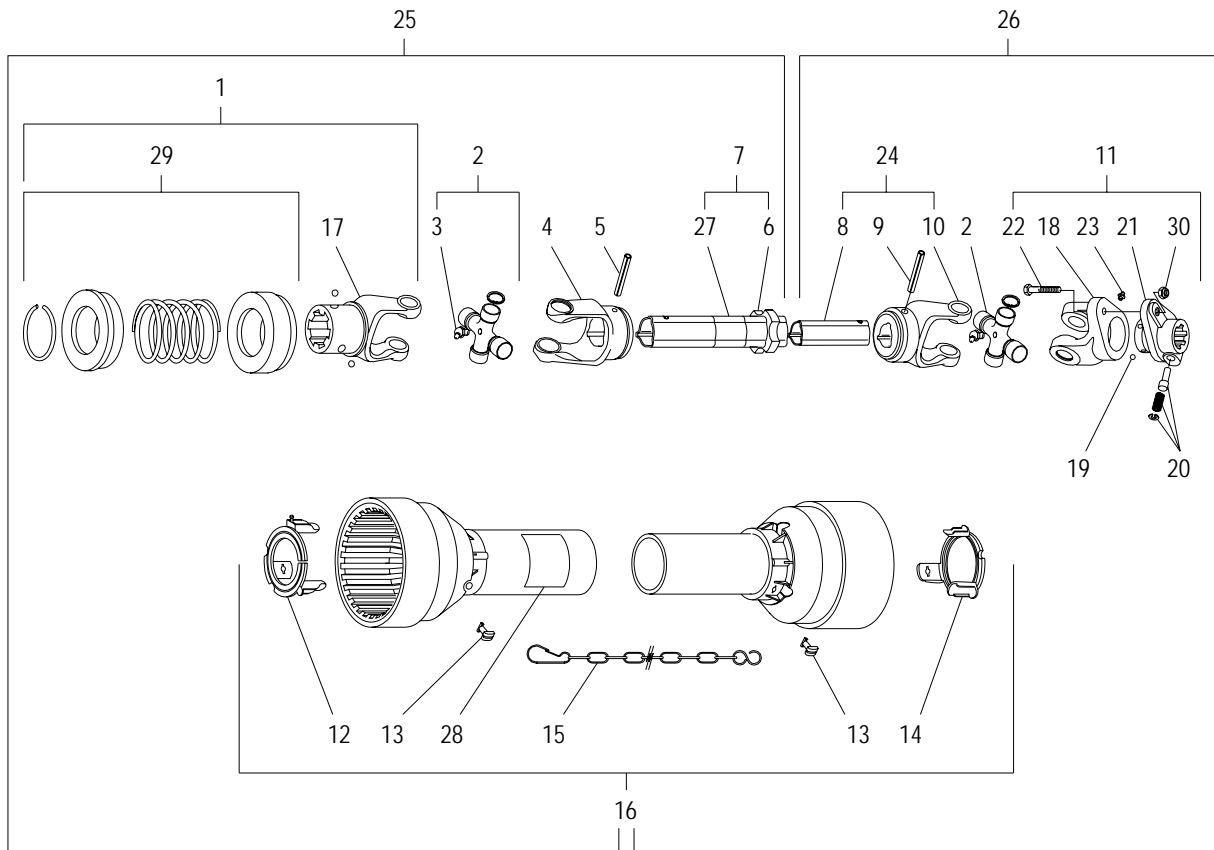

76678 Driveshaft, Center

**540 RPM - 1-3/8"-6 Spline
Manufactured by Comer**

REF. NO.	PART NO.	QTY	DESCRIPTION	REF. NO.	PART NO.	QTY	DESCRIPTION
1	76801	1	Complete Collar Yoke	16	76849	1	Complete Shield
2	64610	2	Cross Journal Set	17	76282	3	Ball 1/2"
3	63956	2	Grease Nipple	18	76618	1	Yoke
4	66112	1	Outer Yoke	19	76202	23	Ball
5	66869	1	Roll Pin For Outer Tube	20	76062	1	Push Pin Set 1-3/8"
6	76072	1	Bushing with Grease Nipple	21	76619	1	Hub
7	76847	1	Complete Outer Tube	22	44525	6	HHCS M10 x 1.5 x 55
8	76848	1	Inner Tube	23	63946	1	Grease Fitting
9	66110	1	Roll Pin for Inner Tube	24	76850	1	Male Tube Yoke w/ Roll Pin
10	66109	1	Inner Yoke	25	76851	1	Half Female Shaft w/ Shield
11	76616	1	Complete Shear Bolt	26	76852	1	Half Male Shaft w/ Shield
12	87995	1	Collar for Outer Tube	27	76786	1	Decal, Danger, Outer Tube
13	87992	6	Bolt	28	78608	1	Decal, Danger, Outer Shield Tube
14	87993	1	Collar for Inner Tube	29	50017480	1	Ball Collar Kit 1-3/8"
15	64814	2	Safety Chain	30	44342	1	Hex Nut M10

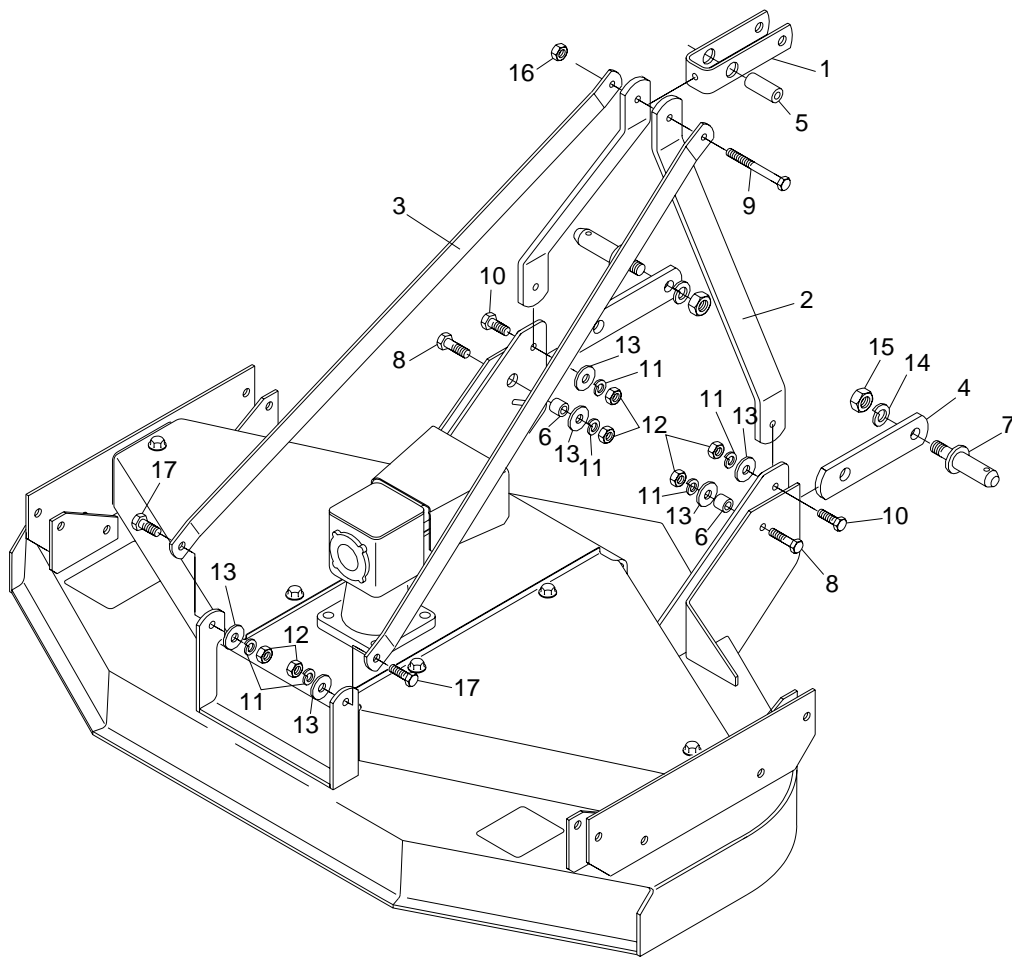

Mast & Supports FP148, 160 & 172

REF. NO.	PART NO.	QTY	DESCRIPTION
1	82815	1	Flex Link
2	88678	2	Mast Half
3	91934	2	Mast Support 72"
	88677	2	Mast Support 60"
4	88686	2	Lift Arm
5	82817	1	Pivot Tube
6	88687	2	Lift Arm Spacer
7	63765	2	Lift Pin Cat. 1
8	20110	2	HHCS 1/2" x 2" G5
9	44030	1	HHCS 1/2" x 5" G5
10	15093	2	HHCS 1/2" x 1-1/2" G5
11	15806	7	Lockwasher 1/2"
12	8151600	6	Hex Nut 1/2"
13	15829	2	Flatwasher 1/2"
		2	Lockwasher 7/8"
14		2	Hex Nut 7/8"
15	44061	2	Hex Nut 7/8"
16	15554	1	Lock Nut 1/2"
17	44094	2	HHCS 1/2" x 1-1/4" G5

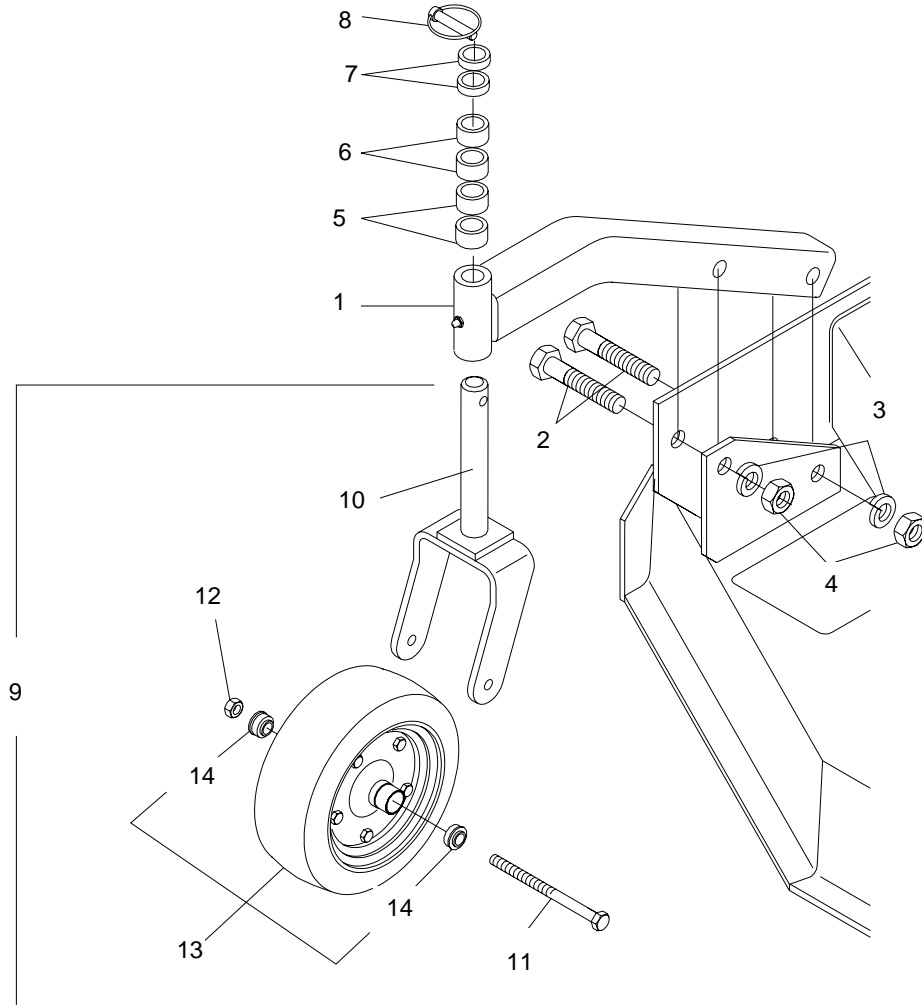

Caster Arm & Wheels

REF. NO.	PART NO.	QTY	DESCRIPTION
1	98286	4	Caster Arm Weldment
2	44107	8	HHCS 5/8" x 3-1/2" G5
3	19486	8	Lockwasher 5/8"
4	15563	8	Hex Nut 5/8"
5	99290	8	Spacer 1"
6	99291	8	Spacer 1/2"
7	99292	8	Spacer 1/4"
8	50017304	4	Lynch Pin
9	98289	4	Solid Tire & Fork Assy.
10	98235	1	Fork for Solid Tire
11	20776	1	HHCS 1/2" x 6"
12	15554	1	Locknut 1/2"
13	97949	1	Tire Assy. w/ Bearing
14	98342	2	Bearing

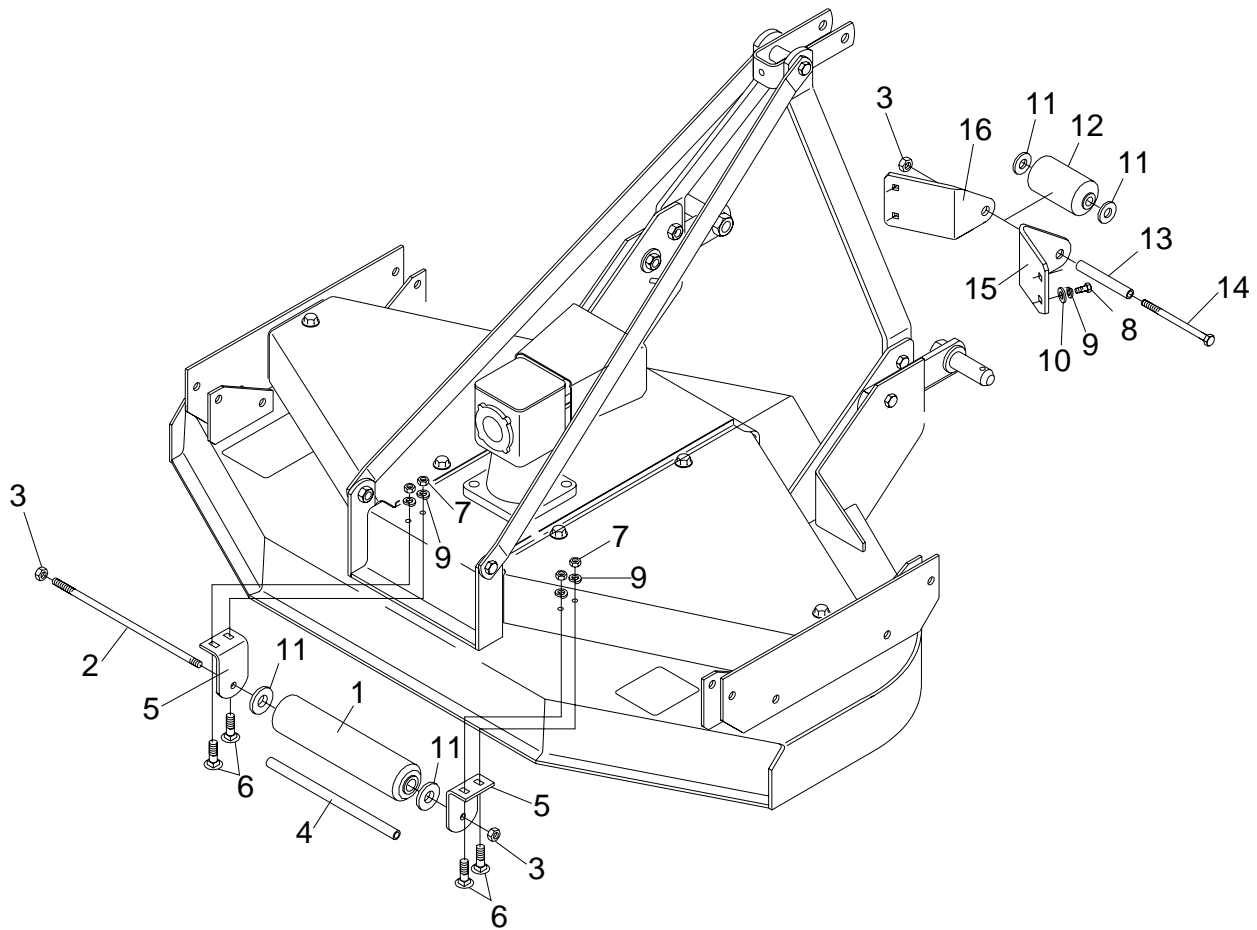

Roller Assemblies

REF. NO.	PART NO.	QTY	DESCRIPTION
1	95415	1	Roller Assembly (Under)
2	50021173	1	Stud
3	15554	3	Locknut 1/2"
4	50021172	1	Sleeve (Under)
5	50028237	2	Roller Bracket
6	44109	4	Carriage Bolt 3/8" x 1" G5
7	8151200	4	Hex Nut 3/8"
8	20034	4	HHCS 3/8" x 1" G5
9	15812	8	Lockwasher 3/8"
10	15830	4	Flatwasher 3/8"
11	15921	4	Flatwasher 3/4"
12	79057	1	Roller Assembly (Front)
13	50021170	1	Sleeve (Front)
14	20580	1	HHCS 1/2" x 6-1/2"
15	50021168	1	Right Hand Roller Mount
16	50021169	1	Left Hand Roller Mount



Locke Turf

307 Highway 52E, Opp, Alabama 36467, (334) 493-1300